

**PLAN**

**NOTES:**

BRICK MASONRY SHALL BE COMMON CLAY BRICK, JUMBO BRICK, OR CONCRETE BRICK.

CONCRETE BOTTOMS SHALL BE PAID AS BRICK MASONRY.

ALL MORTAR JOINTS ARE TO BE 1/2" + 1/8".

FOR DEPTHS OVER 3'-6" USE STEPS ON 16" CENTERS. STEPS SHALL BE IN ACCORDANCE WITH COG STD. #414.

FOR PRECAST CONCRETE MODELS OF THIS STRUCTURE, THE MANUFACTURER SHALL STAMP OR STENCIL ITS LOGO OR NAME ON THE INSIDE AND OUTSIDE OF THE STRUCTURE.

COG STD. #434  
GRATE & FRAME

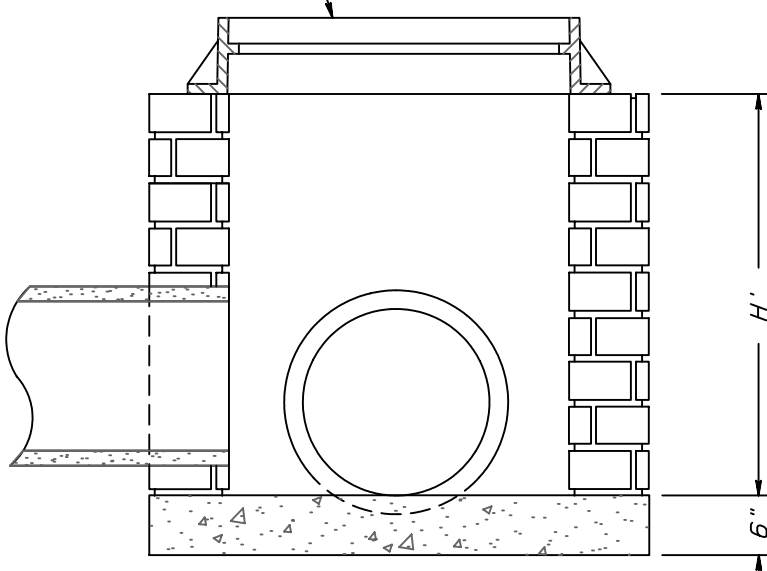

**SECTION A-A**

QUANTITIES	
BASE (C. Y.)	H' (PER FT. HEIGHT)
0.261	0.310 CY

DEDUCTIONS FOR ONE PIPE		
PIPE SIZE	C.M.P.	R.C.P.
12"	0.020	0.032
15"	0.031	0.047
18"	0.044	0.065
24"	0.078	0.122

**CITY OF GREENSBORO**

**STANDARD BRICK MASONRY DROP  
INLET FOR 24" X 36" GRATE**

STD. NO.	REV.
<b>435</b>	08-02 12-07